

阅读申明

- 1.本站收集的数据手册和产品资料都来自互联网，版权归原作者所有。如读者和版权方有任何异议请及时告之，我们将妥善解决。
- 2.本站提供的中文数据手册是英文数据手册的中文翻译，其目的是协助用户阅读，该译文无法自动跟随原稿更新，同时也可能存在翻译上的不当。建议读者以英文原稿为参考以便获得更精准的信息。
- 3.本站提供的产品资料，来自厂商的技术支持或者使用者的心得体会等，其内容可能存在描述上的差异，建议读者做出适当判断。
- 4.如需与我们联系，请发邮件到marketing@iczoom.com，主题请标有“数据手册”字样。

Read Statement

1. The datasheets and other product information on the site are all from network reference or other public materials, and the copyright belongs to the original author and original published source. If readers and copyright owners have any objections, please contact us and we will deal with it in a timely manner.
2. The Chinese datasheets provided on the website is a Chinese translation of the English datasheets. Its purpose is for reader's learning exchange only and do not involve commercial purposes. The translation cannot be automatically updated with the original manuscript, and there may also be improper translations. Readers are advised to use the English manuscript as a reference for more accurate information.
3. All product information provided on the website refer to solutions from manufacturers' technical support or users the contents may have differences in description, and readers are advised to take the original article as the standard.
4. If you have any questions, please contact us at marketing@iczoom.com and mark the subject with "Datasheets" .

The EASY2256 Evaluation System includes specially optimized modular hardware and software components designed to demonstrate the performance of Infineon's FALC[®]56 (PEF 2256 H) in a real-world telecommunications environment.

Each module is controlled by its own device driver and API including SSM (Synchronization Status Message support). The API and SSM run on Infineon's C165UTAH controller together with the firmware.

The EASY 2256 provides system vendors with a highly integrated, software programmable interface reference design for sophisticated E1/T1/J1 framer and Line Interface Unit (LIU) applications based on Infineon's FALC[®]56 transceiver.

The EASY2256 Evaluation System is AT&T and ETSI certified.

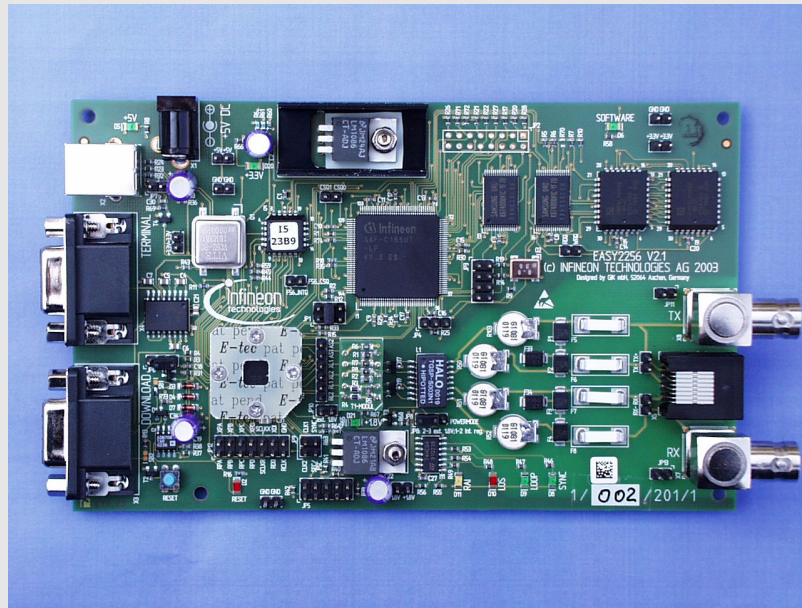

EASY2256

Functionality

- Meets all relevant E1/T1/J1 standards for pulse template, jitter, receiver return loss, line attenuation for short and long haul applications.
- Flexible hardware clocking system with a single clock oscillator as the source for the FALC[®]56 reference clock in E1/T1 or J1 mode
- Features ITU-T K.20/21 approved line interface circuitry
- The FALC[®]56 driver code is downloaded to the board via RS-232 or USB connections to communicate with the Microsoft Windows[®] menu-based WinEASY program.

Hardware Features

- FALC[®]56 device (P-MQFP-80 package) with RJ-45 and BNC connectors

- Highly flexible programmable PCM /system interface available through access connectors
- Single crystal oscillator and transformer for E1/T1/J1 without any resistor changes
- Infineon C165UTAH 16-bit controller
- 1 MByte SRAM system memory
- 1 MByte Flash EEPROM for firmware and user application software
- Two standard serial RS-232 PC interfaces for download and debugging
- High speed USB interface
- LED control for alarms

Software Features

- PC Software for Windows 98/ME and Windows NT/2000
- Automatic detection of available RS-232 interface baud rate

- Log Window for supervising data transfer between Evaluation System and PC
- Track Window to run single API calls in sequences
- Application Manager Window for EEPROM management
- Modular driver system, user specific modification possible
- Download function
- FALC[®]56 API: Easy portable device driver for easy configuration
- All C source code available on CD-ROM
- Direct register access via Chip level
- Application Wizard for FALC[®]56

Accessories

- CD-ROM containing all C-source code, WinEASY and documentation
- Application Wizard for FALC[®]56 and QuadFALC[®]

EASY2256

Evaluation System for FALC[®]56



Never stop thinking.

Hardware Description

The EASY2256 board includes the FALC[®]56 with an external line front end. The FALC[®]56 is connected to a 16-bit CPU C165UTAH. Two serial interfaces provide download and debug capability. The board can be connected to standard E1/T1/J1 test equipment via an RJ-45 or BNC connection.

The AFE represents an optimized generic E1 and T1/J1 platform to meet the pulse shape requirements. The AFE also meets receive and transmit return loss and impedance towards GND specifications without resistor switching for E1-120 Ω, E1-75 Ω and T1-100 Ω cables.

Test connectors provide easy access to all system interface, clock and boundary scan signals.

Four LEDs are included to indicate the synchronization state, loopback status, loss of signal (red alarm), and remote alarm (yellow alarm).

Schematics and layout files are part of the CD-ROM package.

Software Description

In addition to the WinEASY GUI, the software package includes the Device Driver System (DDS) and API driver modules for the FALC[®]56.

The FALC[®]56 API provides state-of-the-art calls and call back functions to configure and maintain the device, and also supports SSM (Synchronization Status Messages). The API is easily ported to various platforms using adaptation layers.

The FALC[®]56-API contains all device specific functions for data and status transfer, including signaling, performance, and alarms, as well as for overall device configuration.

Ordering Information

FALC[®] ICs

Product	Sales Code	Description	Package
FALC56	PEF 2256 H	E1/T1/J1 framer and Line Interface Unit	P-MQFP-80-1

Evaluation Tools

Product	Sales Code	Description	Package
EASY 2256	EASY 2256	Evaluation system for the PEF 2256 H	One board and CD_ROM including software, documentation, and schematics

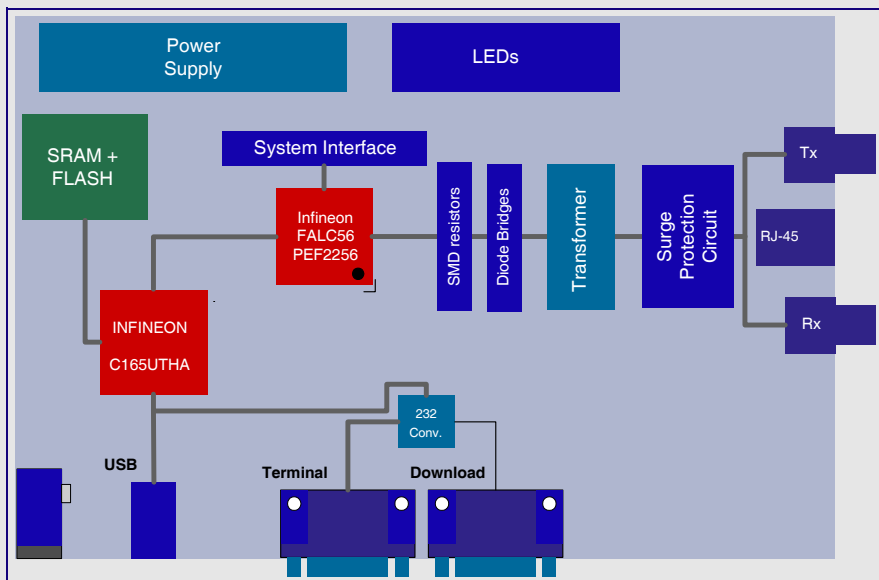

EASY2256
Block Diagram

How to reach us:

<http://www.infineon.com>

Published by
Infineon Technologies AG,
St.-Martin-Strasse 53,
D-81669 München

© Infineon Technologies AG 2003. All Rights Reserved.

Attention please!

The information herein is given to describe certain components and shall not be considered as a guarantee of characteristics.

Terms of delivery and rights to technical change reserved.

We hereby disclaim any and all warranties, including but not limited to warranties of non-infringement, regarding circuits, descriptions and charts stated herein.

Information

For further information on technology, delivery terms and conditions and prices please contact your nearest Infineon Technologies Office.

Warnings

Due to technical requirements components may contain dangerous substances. For information on the types in question please contact your nearest Infineon Technologies Office.

Infineon Technologies Components may only be used in life-support devices or systems with the express written approval of Infineon Technologies, if a failure of such components can reasonably be expected to cause the failure of that life-support device or system, or to affect the safety or effectiveness of that device or system. Life support devices or systems are intended to be implanted in the human body, or to support and/or maintain and sustain and/or protect human life. If they fail, it is reasonable to assume that the health of the user or other persons may be endangered.

Template: tb_tmplt.fm/3/2003-07-01